



Multi-mode Fiber Laser

YLIM-12000-W

Using 976nm high efficiency pumping technology, high EO conversion efficiency, large design redundancy, low long-term use attenuation rate, abnormal closure of a single module is still sustainable operation, is a compact volume, good beam quality, maintenance-free high power fiber laser, both thin plate high-speed cutting and medium thick plate bright surface cutting, perforation efficiency is higher.

Advantages

- Multi-module design, stable operation, less failure;
- Power fluctuation less than 3%, response speed less than 5us, EO efficiency $\geq 42\%$;
- The design redundancy is larger, long-term stable and reliable operation;
- Laser output power closed-loop control, more stable processing;
- Higher laser output energy density, excellent beam quality.

Applications

Widely used in laser cutting, laser welding, laser cladding, laser brazing, laser surface heat treatment, etc., the application of hardware, medical, automotive, shipbuilding, aviation, construction machinery and other fields.

GW's standard certification laser series is based on professional performance, and the design standards pursue parity with international first-line brands. For the international market and high-end user groups, the product design meets the relevant international certification standards, and provides global service network protection services.

- 976nm high efficiency pumping technology, EO efficiency $\geq 42\%$
- CHF technology, improve cutting speed and meet cutting consistency requirements
- ABR anti-reflection design, suitable for a variety of high reflective materials processing application
- The output core diameter can be customized to meet the application requirements of multiple scenarios



EO conversion efficiency $\geq 42\%$



Easily process high anti materials



Power closed loop control



Custom waveform output

Multi-mode Fiber Laser

YLIM-12000-W

Product specification parameter	YLIM-12000-W
Output Power (watt)	12000
Operating Mode	CW/Pulse/Built-in program
Output Power Range (%)	1-100
Output Laser Wavelength (nm)	1070±10
Beam Quality	BPP≤3
Interface Type	Q+
Delivery Fiber Core Diameter (conventional configuration, optional)	70um
Cooling Method	Water-cooling
Ambient Temperature Range (°C)	5-45
Input Voltage	380VAC/50Hz
Dimension (mm)	835x 433 x 840 (L×W×H)
Weight (kg)	325

Unit: mm

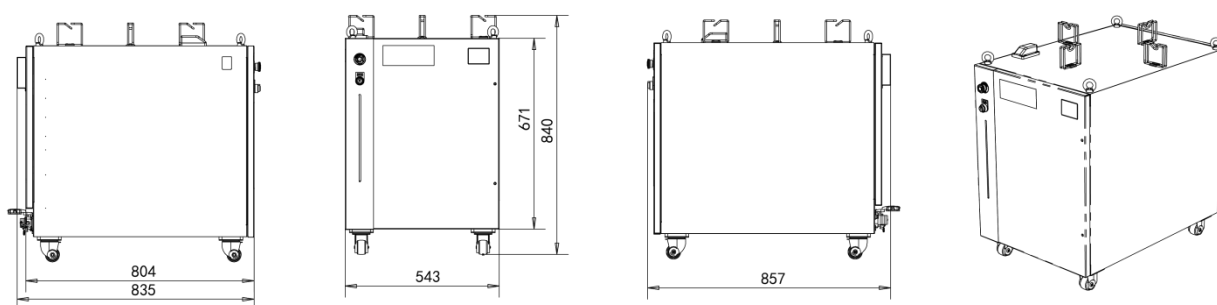

Legal Notice: All product information is believed to be accurate and subject to change without notice.

Legal statement:

GW smart fiber laser products are designed in strict accordance with safety regulations. All production is in accordance with international standards and regulations currently in force in the country. Each GW laser has a warning sign as shown in the figure.

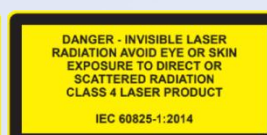
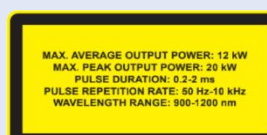

GW(Shanghai) Laser Technology Co.,Ltd. Tel: +86 2139721122 Email: sales@gw-laser.tech

Web: www.gw-laser.tech Addr: Building 5-1, No.398, Shuanglian Road, Xujing Town, Qingpu District, Shanghai