



AAC CW Fiber Laser

YLPS-1500-A

Adopt the world's first active air conditioning direct cooling technology, accurate temperature control, good heat dissipation effect, high laser stability, no water cooling system trouble. The product can achieve 24 hours continuous and stable operation, the product design redundancy is high, and the beam quality is excellent.

Advantages

- AAC technology, without water chiller, maintenance-free
- Ambient temperature -20~50°C , non-stop operation for 24 hours
- Higher integration and easier installation
- Lower power consumption and more energy-saving

Applications

Can cooperate with laser processing head, galvanometer and robot, machine tool system integration, do laser fine cutting, precision welding processing, used in 3C, hardware, medical, automotive, aviation and other fields.

The professional performance laser series of GW is aimed at customers who have the pursuit of product performance indicators, the replacement of imported products or the product functionality requirements. Product design to the first-line brand, with better product performance indicators, perfect functions, design redundancy is greater, to provide customers with more value-added space.

- AAC technology, accurate temperature control
- Ultra-low power attenuation, stable performance, double durability
- Excellent beam quality, anti-reflection design, suitable for a variety of high reflective materials processing applications
- SMAT Intelligent operating system



EO conversion efficiency $\geq 42\%$



Easily process high anti materials



SMAT Intelligent operating system



can run continuously for 24h

AAC CW Fiber Laser

YLPS-1500-A

Product specification parameter	YLPS-1500-A
Output Power (watt)	1500
Operating Mode	CW/Pulse/Built-in program
Output Power Range (%)	1-100
Output Laser Wavelength (nm)	1070±10
Beam Quality	$M^2 \leq 1.4$
Interface Type	QBH
Delivery Fiber Core Diameter (conventional configuration, optional)	25um
Cooling Method	Active air cooling
Ambient Temperature Range (°C)	-20~50
Input Voltage	220VAC/50Hz
Dimension (mm)	699 x 371 x 573 (L×W×H)
Weight (kg)	< 60

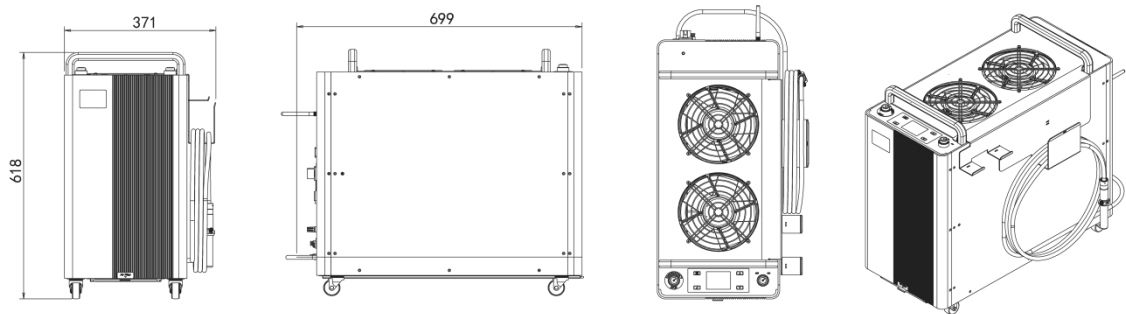

Legal Notice: All product information is believed to be accurate and subject to change without notice.

Legal statement:

GW smart fiber laser products are designed in strict accordance with safety regulations. All production is in accordance with international standards and regulations currently in force in the country. Each GW laser has a warning sign as shown in the figure.

MAX. AVERAGE OUTPUT POWER: 12 kW
MAX. PEAK OUTPUT POWER: 20 kW
PULSE DURATION: 0.2-2 ms
PULSE REPETITION RATE: 50 Hz-10 kHz
WAVELENGTH RANGE: 900-1200 nm

DANGER - INVISIBLE LASER
RADIATION AVOID EYE OR SKIN
EXPOSURE TO DIRECT OR
SCATTERED RADIATION
CLASS 4 LASER PRODUCT

IEC 60825-1:2014



GW(Shanghai) Laser Technology Co.,Ltd. Tel: +86 2139721122 Email: sales@gwlaser.tech

Web: www.gwlaser.tech Addr: Building 5-1, No.398, Shuanglian Road, Xujing Town, Qingpu District, Shanghai