



Single-mode Fiber Laser

YLPS-6000-W

Single-module continuous fiber laser adopts 976nm high efficiency bidirectional pumping technology, high anti-reverse design, stable performance, high electro-optical conversion rate, and has the advantages of high cutting efficiency and strong welding ability. New modular design, high space utilization.

Advantages

- New platform design, smaller, lighter, easier integration
- Real-time response time < 5us
- Versatile external interface, customized 64 programs
- Output power closed-loop control

Applications

Widely used in laser cutting, laser welding, laser cladding, laser brazing, laser surface heat treatment, etc., the application of hardware, medical, automotive, shipbuilding, aviation, construction machinery and other fields.

The professional performance laser series of GW is aimed at customers who have the pursuit of product performance indicators, the replacement of imported products or the product functionality requirements. Product design to the first-line brand, with better product performance indicators, perfect functions, design redundancy is greater, to provide customers with more value-added space.

- 976nm high efficiency bidirectional pumping technology, EO efficiency $\geq 42\%$
- Excellent beam quality and excellent performance
- ABR anti-reflection design, suitable for a variety of high reflective materials processing applications
- The output core diameter can be customized to meet the application requirements of multiple scenarios



EO conversion
efficiency $\geq 42\%$



Easily process
high anti materials



Custom waveform
output



Remote lot access

Single-mode Fiber Laser

YLPS-6000-W

| Product specification parameter | YLPS-6000-W |
|--|---------------------------|
| Output Power (watt) | 6000 |
| Operating Mode | CW/Pulse/Built-in program |
| Output Power Range (%) | 1-100 |
| Output Laser Wavelength (nm) | 1070±10 |
| Beam Quality | BPP≤2 |
| Interface Type | QBH |
| Delivery Fiber Core Diameter (conventional configuration, optional) | 50um |
| Cooling Method | Water-cooling |
| Ambient Temperature Range (°C) | 5-45 |
| Input Voltage | 380VAC/50Hz |
| Dimension (mm) | 667 x 432 x 131 (L×W×H) |
| Weight (kg) | < 60 |

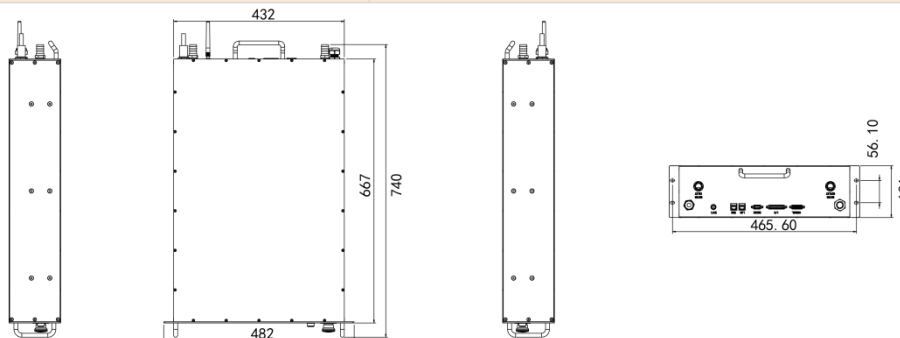

Unit: mm

Legal Notice: All product information is believed to be accurate and subject to change without notice.

Legal statement:

GW smart fiber laser products are designed in strict accordance with safety regulations. All production is in accordance with international standards and regulations currently in force in the country. Each GW laser has a warning sign as shown in the figure.

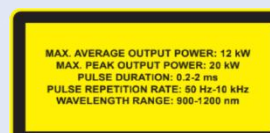

GW(Shanghai) Laser Technology Co.,Ltd. Tel: +86 2139721122 Email: sales@gwlasertech

Web: www.gwlasertech Addr: Building 5-1, No.398, Shuanglian Road, Xujing Town, Qingpu District, Shanghai