



Single-mode Fiber Laser

YLLS-Plus-6000-W

Newly updated 19" rack-mountable design, better power stability, lighter weight and smaller form factor. uni-body design for easier maintenance.



Advantages

- 19-inch 3U rack design cabinet, easier integration
- ABR technology for various high-reflective material
- 976nm Pumping technology, EO conversion efficiency > 40%
- Customized Delivery Fiber Core Diameter, better beam quality, better BPP
- PLUS series is optimized for thin and mid-thick sheet cutting process, better performance

Applications

Cutting, welding, drilling, metal 3D printing of stainless steel, carbon steel, Aluminum, copper, brass, silver, gold, etc. up to 25mm

GW's economical laser series is oriented to the user group with the ultimate cost performance requirement, taking economy as the core, taking into account high quality and low price, which can fully meet the daily production and use needs of customers.

- New optical structure design with higher beam quality
- High laser output stability, higher integration, more optimized structure
- ABR anti-reflection design, suitable for a variety of high reflective materials processing applications
- The output core diameter can be customized to meet multiple application requirements



EO conversion efficiency $\geq 40\%$



Easily process high anti materials



High integration



Remote lot access

Single-mode Fiber Laser

YLLS-Plus-6000-W

Product specification parameter	YLLS-Plus-6000-W
Output Power (watt)	6000
Operating Mode	CW/Pulse
Output Power Range (%)	1-100%
Output Laser Wavelength (nm)	1080±10
Beam Quality	BPP≤2
Interface Type	QBH
Delivery Fiber Core Diameter (conventional configuration, optional)	50um
Cooling Method	Water-cooling
Ambient Temperature Range (°C)	5-45
Input Voltage	380VAC/50Hz
Dimension (mm)	667 x 432 x 131 (L×W×H)
Weight (kg)	< 60

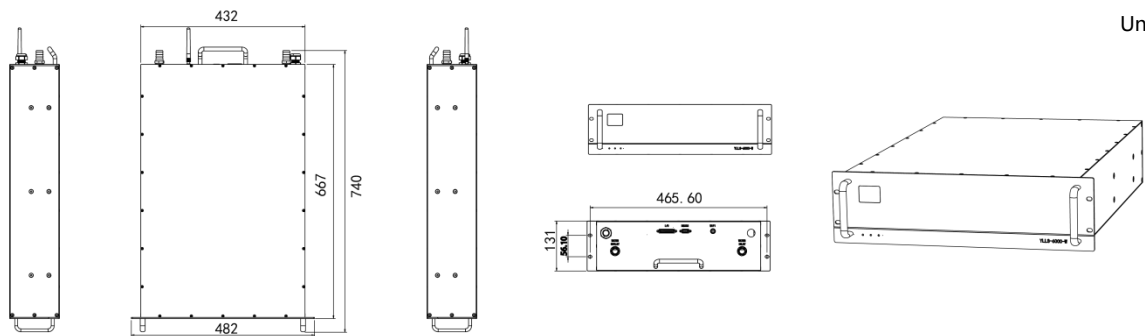

Legal Notice: All product information is believed to be accurate and subject to change without notice.

Legal statement:

GW smart fiber laser products are designed in strict accordance with safety regulations. All production is in accordance with international standards and regulations currently in force in the country. Each GW laser has a warning sign as shown in the figure.

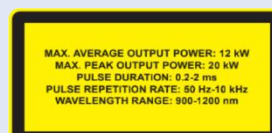

GW(Shanghai) Laser Technology Co.,Ltd. Tel: +86 2139721122 Email: sales@gwlasertech

Web: www.gwlasertech Addr: Building 5-1, No.398, Shuanglian Road, Xujing Town, Qingpu District, Shanghai