



## Single-mode Fiber Laser

### YLIS-1000-W

Single-module continuous fiber laser adopts modular design, integrated fully enclosed chassis, adopts high-efficiency 976nm bidirectional pumping technology, high EO conversion efficiency, high brightness, high reliability, small output fiber core diameter, with high beam quality, mainly used for high inverse material processing, laser fine cutting, precision welding processing.

#### Advantages

- Standard 19-inch chassis 1.5U height design, easy to integrate;
- High power output stability, support output power closed-loop control, high beam quality;
- The output core diameter can be customized to meet the application requirements of multiple scenarios;
- 976nm high efficiency pumping technology, EO efficiency  $\geq 42\%$ .

#### Applications

Can cooperate with laser processing head, galvanometer and robot, machine tool system integration, mainly used in high reflection material processing, laser fine cutting, precision welding processing, used in 3C, hardware, medical, automotive, aviation and other fields.

GW's standard certification laser series is based on professional performance, and the design standards pursue parity with international first-line brands. For the international market and high-end user groups, the product design meets the relevant international certification standards, and provides global service network protection services.

- Modular design, integrated fully enclosed chassis
- High beam quality, high laser output stability, and higher integration
- ABR anti-reflection design, suitable for a variety of high reflective materials processing applications
- The output core diameter can be customized to meet the application requirements of multiple scenarios



EO conversion  
efficiency  $\geq 42\%$



Easily process  
high anti materials



$M^2 \leq 1.3$



Custom waveform  
output

# Single-mode Fiber Laser

## YLIS-1000-W

Product specification parameter	YLIS-1000-W
Output Power (watt)	1000
Operating Mode	CW/Pulse/Built-in program
Output Power Range (%)	1-100
Output Laser Wavelength (nm)	1070±10
Beam Quality	$M^2 \leq 1.3$
Interface Type	QBH
Delivery Fiber Core Diameter (conventional configuration, optional)	20um
Cooling Method	Water-cooling
Ambient Temperature Range (°C)	5-45
Input Voltage	220VAC/50Hz
Dimension (mm)	513 x 482 x 66 (L×W×H)
Weight (kg)	< 20

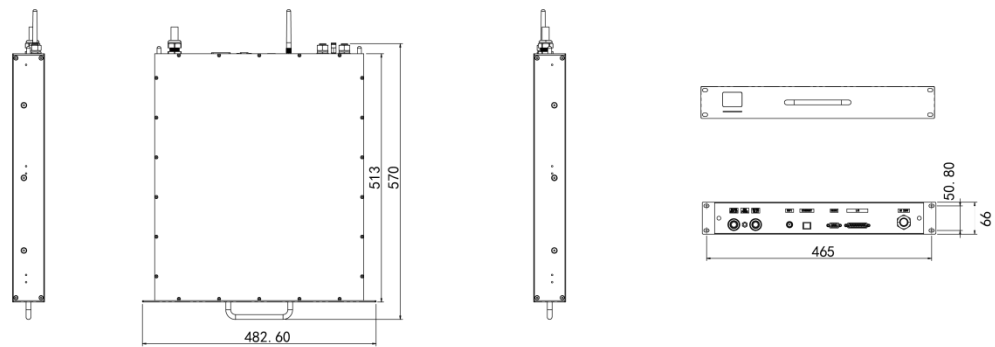

Legal Notice: All product information is believed to be accurate and subject to change without notice.

Legal statement:

GW smart fiber laser products are designed in strict accordance with safety regulations. All production is in accordance with international standards and regulations currently in force in the country. Each GW laser has a warning sign as shown in the figure.

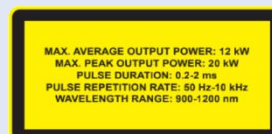

GW(Shanghai) Laser Technology Co.,Ltd. Tel: +86 2139721122 Email: sales@gwlaser.tech

Web: [www.gwlaser.tech](http://www.gwlaser.tech) Addr: Building 5-1, No.398, Shuanglian Road, Xujing Town, Qingpu District, Shanghai